



CTP GRIP-TIE

-- Submittal --



CTP 5300 SERIES ANCHOR

Veneer \geq 3"

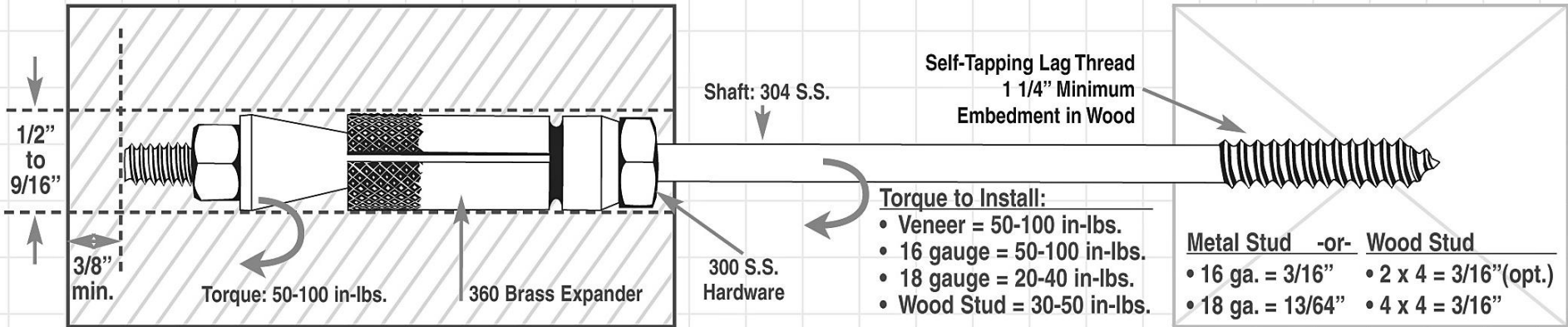

Length

5 1/2 " (138mm)

7 1/2 " (188mm)

9 1/2 " (238mm)

6 1/2 " (163mm)

8 1/2 " (213mm)

Other _____

Approval

• Brass: ASTM B16, Type 360

• S.S : ASTM 580A, Type 304

Project: _____

Submitted By: _____ Date: _____

7974 W. Orchard Dr. * Michigan City, IN 46360 * Phone:(219)878-1427*Fax: (219)874-3626

Email: stevectp@comcast.net * www.ctpanchors.com